

INSTALLATION MANUAL

R-410A HORIZONTAL DISCHARGE AIR CONDITIONING

MODELS: 13 SEER

TCHD SERIES

1.5 TO 5 TONS – 1 & 3 PHASE



LIST OF SECTIONS

GENERAL	1	SYSTEM CHARGE	5
SAFETY	1	ELECTRICAL CONNECTIONS	6
UNIT INSTALLATION	2	INSTRUCTING THE OWNER	12
TXV INSTALLATION	5	WIRING DIAGRAM	13
EVACUATION	5	START UP SHEET	15

LIST OF FIGURES

Typical Installation	2	Thermostat Chart - Single Stage AC with PSC Air Handler	9
Installation of Vapor Line	4	Thermostat Chart - Single Stage AC with PSC Furnace	10
Underground Installation	4	Thermostat Chart - Single Stage AC with PSC Furnace	11
Heat Protection	4	Wiring Diagram (Single-Phase)	13
Outdoor Unit Field Wiring Control Box	7	Wiring Diagram (Three-Phase)	14
Typical Field Wiring (Air Handler / Electrical Heat)(Single-Phase)	7		
Typical Field Wiring (Air Handler / Electrical Heat)(Three-Phase)	7		
Thermostat Chart - Single Stage AC with PSC Air Handler	8		

LIST OF TABLES

Application Limitations	2	R-410A Saturation Properties	6
-------------------------------	---	------------------------------------	---

SECTION I: GENERAL

The outdoor units are designed to be connected to a matching indoor coil with sweat connect lines. Sweat connect units are factory charged with refrigerant for a matching indoor coil plus 15 feet of field supplied lines.

Matching indoor coils require a matching thermostatic expansion valve (TXV) - refer to the Tabular Data Sheet or Technical Guide. The refrigerant charge may need to be changed for some indoor-outdoor unit combinations, elevation differences or total line lengths. Refer to Application Data covering "General Piping Recommendations and Refrigerant Line Length" (Part Number 247077).

SECTION II: SAFETY



This is a safety alert symbol. When you see this symbol on labels or in manuals, be alert to the potential for personal injury.

Understand and pay particular attention to the signal words **DANGER**, **WARNING**, or **CAUTION**.

DANGER indicates an **imminently** hazardous situation, which, if not avoided, **will result in death or serious injury**.

WARNING indicates a **potentially** hazardous situation, which, if not avoided, **could result in death or serious injury**.

CAUTION indicates a potentially hazardous situation, which, if not avoided **may result in minor or moderate injury**. It is also used to alert against unsafe practices and hazards involving only property damage.

CAUTION

This product must be installed in strict compliance with the enclosed installation instructions and any applicable local, state, and national codes including, but not limited to building, electrical, and mechanical codes.

WARNING

Improper installation may create a condition where the operation of the product could cause personal injury or property damage. Improper installation, adjustment, alteration, service or maintenance can cause injury or property damage. Refer to this manual for assistance or for additional information, consult a qualified contractor, installer or service agency.

CAUTION

*R-410A systems operate at higher pressures than R-22 systems. Do not use R-22 service equipment or components on R-410A equipment. Service equipment **Must Be Rated** for R-410A.*

INSPECTION

As soon as a unit is received, it should be inspected for possible damage during transit. If damage is evident, the extent of the damage should be noted on the carrier's delivery receipt. A separate request for inspection by the carrier's agent should be made in writing. See Local Distributor for more information.

Requirements For Installing/Serviceing R-410A Equipment

- Gauge sets, hoses, refrigerant containers, and recovery system must be designed to handle the POE type oils, and the higher pressures of R-410A.
- Manifold sets should be 800 PSIG high side and 250 PSIG low side with 550 PSIG low side retard.
- All hoses must have a 700 PSIG service pressure rating.
- Leak detectors should be designed to detect HFC refrigerant.
- Recovery equipment (including refrigerant recovery containers) must be specifically designed to handle R-410A.
- Do not use an R-22 TXV.
- A liquid-line filter drier is required on every unit.

LIMITATIONS

The unit should be installed in accordance with all National, State and Local Safety Codes and the limitations listed below:

1. Limitations for the indoor unit, coil, and appropriate accessories must also be observed.
2. The outdoor unit must not be installed with any duct work in the air stream. The outdoor fan is the propeller type and is not designed to operate against any additional external static pressure.
3. The maximum and minimum conditions for operation must be observed to ensure a system that will give maximum performance with minimum service.

TABLE 1: Application Limitations

Ambient Air Temperature on Outdoor Coil		Air Temperature on Indoor Coil	
Min. DB	Max. DB	Min. WB	Max. WB
50 °F	115 °F	57 °F	72 °F

4. The unit should not be operated at outdoor temperatures below 50° F without an approved low ambient operation accessory kit installed.
5. The maximum allowable line length for this product is 200 feet.

SECTION III: UNIT INSTALLATION

LOCATION

Before starting the installation, select and check the suitability of the location for both the indoor and outdoor unit. Observe all limitations and clearance requirements.

The outdoor unit must have sufficient clearance for air entrance to the condenser coil, air discharge, and service access. See Figure 1.

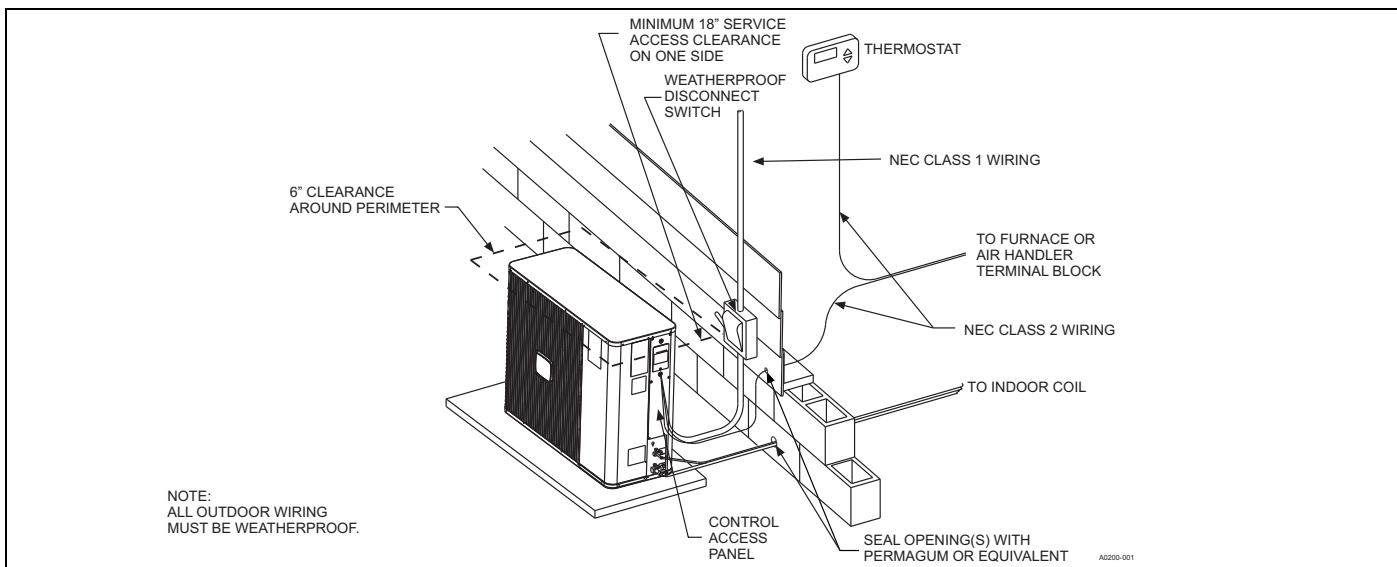

FIGURE 1: Typical Installation

NOTICE

For multiple unit installations, units must be spaced a minimum of 18 inches apart (coil face to coil face).

If the unit is to be installed on a hot sun exposed roof or a paved ground area that is seasonally hot, the unit should be raised sufficiently above the roof or ground to avoid taking the accumulated layer of hot air into the outdoor unit.

Provide adequate structural support.

ADD-ON REPLACEMENT/RETROFIT

When this unit is being used as a replacement for an R-22 unit, it is required that the outdoor unit, indoor coil, and metering device all be replaced. The following steps should be performed in order to insure proper system operation and performance. Line-set change out is also recommended.

1. Change-out of the indoor coil to an approved R-410A coil/condensing unit combination with the appropriate metering device.
2. Change-out of the line-set when replacing an R-22 unit with an R410-A unit is highly recommended to reduce cross-contamination of oils and refrigerants.
3. If change-out of the line set is not practical, then the following precautions should be taken.
 - Inspect the line set for kinks, sharp bends, or other restrictions, and for corrosion.
 - Determine if there are any low spots which might be serving as oil traps.
 - Flush the line set with a commercially available flush kit to remove as much of the existing oil and contaminants as possible.
 - Install a suction line filter-drier to trap any remaining contaminants, and remove after 50 hours of operation.
4. If the outdoor unit is being replaced due to a compressor burnout, then installation of a 100% activated alumina suction-line filter drier in the suction-line is required, in addition to the factory installed liquid-line drier. Operate the system for 10 hours. Monitor the suction drier pressure drop. If the pressure drop exceeds 3 psig, replace both the suction-line and liquid-line driers. After a total of 10 hours run time where the suction-line pressure drop has not exceeded 3 psig, replace the liquid line drier, and remove the suction-line drier. Never leave a suction-line drier in the system longer than 50 hours of run time.

GROUND INSTALLATION

The unit should be installed on a solid base that is 2" above grade and will not shift or settle, causing strain on the refrigerant lines and possible leaks. Maintain the clearances shown in Figure 1 and install the unit in a level position. The base pad should not come in contact with the foundation or side of the structure because sound may be transmitted to the residence.

The length of the refrigerant tubing between the outdoor unit and indoor coil should be as short as possible to avoid capacity and efficiency losses. Excessive spacing of the outdoor unit from the home can result in the refrigerant lines being restricted by trampling or being punctured by lawn mowers. Locate the outdoor unit away from bedroom windows or other rooms where sound might be objectionable.

Adverse effects of snow or sleet accumulating on the outdoor coil can be eliminated by placing the outdoor unit where the prevailing wind does not blow across the unit. Trees, shrubs, corners of buildings, and fences standing off from the coil can reduce capacity loss due to wind chill effect.

Provide ample clearance from shrubs to allow adequate air to pass across the outdoor coil without leaves or branches being pulled into the fan.

ROOF INSTALLATION

When installing units on a roof, the structure must be capable of supporting the total weight of the unit, including a pad, lintels, rails, etc., which should be used to minimize the transmission of sound or vibration into the conditioned space.

WALL MOUNT INSTALLATION

Care must be taken to mount the outdoor unit on a solid base that is sloped to shed water, secure from settlement, and is isolated from the structural foundation or walls to prevent sound and vibration transmission into the living space. In addition heat pump units must be elevated above anticipated snow accumulation levels to allow for proper defrost drainage and airflow.

On occasion, site conditions may require direct wall mounted brackets to be used to locate and support the outdoor unit. In these applications, care must be taken to address unit base pan support, structural integrity, safe access and serviceability, as well as the possible sound and vibration transmission into the structure. These applications are best served by a properly engineered solution.

LIQUID LINE FILTER-DRIER

The air conditioning unit's filter/dryer is located on the liquid line.

NOTICE

Replacements for the liquid line drier must be exactly the same as marked on the original factory drier. See Source 1 for O.E.M. replacement driers.

CAUTION

Failure to do so or using a substitute drier or a granular type may result in damage to the equipment.

Filter-Drier Source 1 Part No.	Apply with Models
S1-02922195000	All

PIPING CONNECTIONS

The outdoor condensing unit must be connected to the indoor evaporator coil using field supplied refrigerant grade (ACR) copper tubing that is internally clean and dry. Units should be installed only with the tubing sizes for approved system combinations as specified in tabular data sheet. The charge given is applicable for total tubing lengths up to 15 feet. When more than 50 ft of interconnecting tubing and more than 30 ft of vertical lift is used, consult the Application Data (part number 247077). For long-line applications, interconnecting lines over 100 ft must be installed with liquid line solenoid. Refer to Technical Guide or Tabular Data Sheet for maximum length, lifts, and drop.

NOTICE

Using a larger than specified line size could result in oil return problems. Using too small a line will result in loss of capacity and other problems caused by insufficient refrigerant flow. Slope horizontal vapor lines at least 1" every 20 feet toward the outdoor unit to facilitate proper oil return.

CAUTION

This system uses R-410A refrigerant which operates at higher pressures than R-22. No other refrigerant may be used in this system. Gauge sets, hoses, refrigerant containers, and recovery system must be designed to handle R-410A. If you are unsure, consult the equipment manufacturer.

WARNING

Never install a suction-line filter drier in the liquid line of an R-410A system. Failure to follow this warning can cause a fire, injury or death.

PRECAUTIONS DURING LINE INSTALLATION

1. Install the lines with as few bends as possible. Care must be taken not to damage the couplings or kink the tubing. Use clean hard drawn copper tubing where no appreciable amount of bending around obstruction is necessary. If soft copper must be used, care must be taken to avoid sharp bends which may cause a restriction.
2. The lines should be installed so that they will not obstruct service access to the coil, air handling system, or filter.
3. Care must also be taken to isolate the refrigerant lines to minimize noise transmission from the equipment to the structure.
4. The vapor line must be insulated with a minimum of 1/2" foam rubber insulation (Armaflex or equivalent). Liquid lines that will be exposed to direct sunlight, high temperatures, or excessive humidity must also be insulated.
5. Tape and suspend the refrigerant lines as shown. DO NOT allow tube metal-to-metal contact. See Figure 2.
6. Use PVC piping as a conduit for all underground installations as shown in Figure 3. Buried lines should be kept as short as possible to minimize the build up of liquid refrigerant in the vapor line during

- Pack fiberglass insulation and a sealing material such as perma-gum around refrigerant lines where they penetrate a wall to reduce vibration and to retain some flexibility.
- For systems with total line length exceeding 70 feet, see APPLICATION DATA and worksheet "General Piping Recommendations and Refrigerant Line Length" for vapor and liquid line sizing, calibration of liquid line pressure loss or gain, determination of vapor line velocity, elevation limitations, orifice connections, system charging, traps, etc.

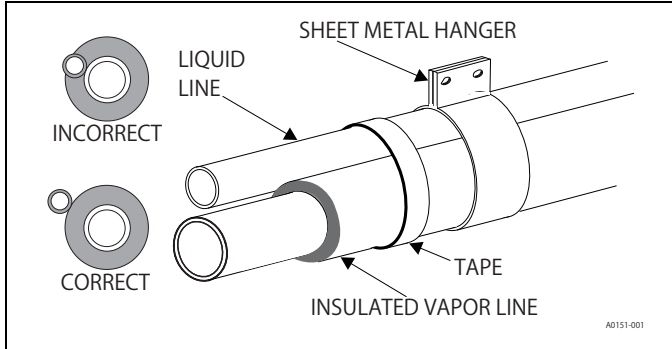

FIGURE 2: Installation of Vapor Line

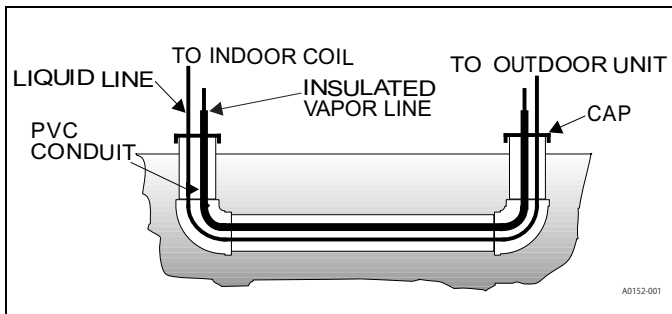

FIGURE 3: Underground Installation

PRECAUTIONS DURING BRAZING OF LINES

All outdoor unit and evaporator coil connections are copper-to-copper and should be brazed with a phosphorous-copper alloy material such as Silfos-5 or equivalent. DO NOT use soft solder. The outdoor units have reusable service valves on both the liquid and vapor connections. The total system refrigerant charge is retained within the outdoor unit during shipping and installation. The reusable service valves are provided to evacuate and charge per this instruction.

Serious service problems can be avoided by taking adequate precautions to assure an internally clean and dry system.

CAUTION

Dry nitrogen should always be supplied through the tubing while it is being brazed, because the temperature required is high enough to cause oxidation of the copper unless an inert atmosphere is provided. The flow of dry nitrogen should continue until the joint has cooled. Always use a pressure regulator and safety valve to insure that only low pressure dry nitrogen is introduced into the tubing. Only a small flow is necessary to displace air and prevent oxidation.

PRECAUTIONS DURING BRAZING SERVICE VALVE

Precautions should be taken to prevent heat damage to service valve by wrapping a wet rag around it as shown in Figure 4. Also, protect all painted surfaces, insulation, and plastic base during brazing. After brazing, cool joint with wet rag.

WARNING

This is not a back seating valve. The service access port has a valve core. Opening or closing valve does not close service access port.

If the valve stem is backed out past the chamfered retaining wall, the O-ring can be damaged causing leakage or system pressure could force the valve stem out of the valve body possibly causing personal injury.

Valve can be opened by removing the plunger cap and fully inserting a hex wrench into the stem and backing out counter-clockwise until valve stem just touches the chamfered retaining wall.

Connect the refrigerant lines using the following procedure:

- Remove the cap and Schrader core from both the liquid and vapor service valve service ports at the outdoor unit. Connect low pressure nitrogen to the liquid line service port.
- Braze the liquid line to the liquid valve at the outdoor unit. Be sure to wrap the valve body with a wet rag. Allow the nitrogen to continue flowing.
- Carefully remove the plugs from the evaporator liquid and vapor connections at the indoor coil.

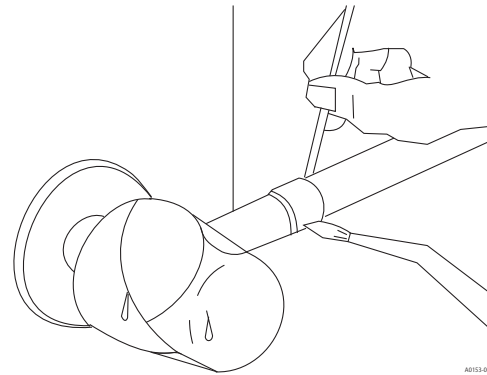

FIGURE 4: Heat Protection

CAUTION

Do not install any coil in a furnace which is to be operated during the heating season without attaching the refrigerant lines to the coil. The coil is under 30 to 35 psig inert gas pressure which must be released to prevent excessive pressure build-up and possible coil damage.

- Braze the liquid line to the evaporator liquid connection. Nitrogen should be flowing through the evaporator coil.
- Slide the grommet away from the vapor connection at the indoor coil. Braze the vapor line to the evaporator vapor connection. After the connection has cooled, slide the grommet back into original position.
- Protect the vapor valve with a wet rag and braze the vapor line connection to the outdoor unit. The nitrogen flow should be exiting the system from the vapor service port connection. After this connection has cooled, remove the nitrogen source from the liquid fitting service port.
- Replace the Schrader core in the liquid and vapor valves.
- Go to "SECTION IV" or "SECTION V" for orifice or TXV installation depending on application.
- Leak test all refrigerant piping connections including the service port flare caps to be sure they are leak tight. DO NOT OVERTIGHTEN (between 40 and 60 inch - lbs. maximum).

NOTICE

Line set and indoor coil can be pressurized to 250 psig with dry nitrogen and leak tested with a bubble type leak detector. Then release the nitrogen charge.

Do not use the system refrigerant in the outdoor unit to purge or leak test.

10. Evacuate the vapor line, evaporator, and liquid line to 500 microns or less.
11. Replace cap on service ports. Do not remove the flare caps from the service ports except when necessary for servicing the system.

CAUTION

Do not connect manifold gauges unless trouble is suspected. Approximately 3/4 ounce of refrigerant will be lost each time a standard manifold gauge is connected.

12. Release the refrigerant charge into the system. Open both the liquid and vapor valves by removing the plunger cap and with an allen wrench back out counter-clockwise until valve stem just touches the chamfered retaining wall. If the service valve is a ball valve, use a Crescent wrench to turn valve stem one-quarter turn counterclockwise to open. Do not overturn or the valve stem may break or become damaged. See "PRECAUTIONS DURING BRAZING SERVICE VALVE".
13. Replace plunger cap finger tight, then tighten an additional 1/12 turn (1/2 hex flat). Cap must be replaced to prevent leaks.

WARNING

Never attempt to repair any brazed connections while the system is under pressure. Personal injury could result.

See "System Charge" section for checking and recording system charge.

Supplied with the outdoor unit is a Schrader Valve Core and Orifice for highest sales volume indoor coil. The valve core must be installed in equalizer fitting of the indoor coil.

SECTION IV: TXV INSTALLATION

The following are the basic steps for installation. For detailed instructions, refer to the Installation Instructions accompanying the TXV kit. Install TXV kit as follows:

IMPORTANT

Only 1TVM900 series valves are to be used on this product.

1. Relieve the holding charge by pulling off the rubber cap plug on the suction manifold line of the coil.
2. After holding charge is completely discharged, loosen and remove the schrader cap seal.
3. Loosen and remove distributor cap seal.
4. Install the thermal expansion valve to the orifice distributor assembly with supplied fittings. Hand tighten and turn an additional 1/4 turn to seal. Do not overtighten fittings.
5. Install the liquid line to the top of the thermal expansion valve with fitting supplied with the liquid line. Hand modify the liquid line to align with casing opening. Hand tighten the liquid line and an additional 1/4 turn to seal.
6. Install the TXV equalizer line into the vapor line as follows:

- a. Hand tighten the 1/4" SAE nut to the schrader fitting and an additional 1/3 turn to seal.
7. Install the TXV bulb to the vapor line near the equalizer line, using the bulb clamp(s) furnished with the TXV assembly. Ensure the bulb is making maximum contact.
 - a. Bulb should be installed on a horizontal run of the vapor line if possible. The bulb should be installed on top of the line.
 - b. If bulb installation is made on a vertical run, the bulb should be located at least 16 inches from any bend, and on the tubing sides opposite the plane of the bend. The bulb should be positioned with the bulb tail at the top, so that the bulb acts as a reservoir.
 - c. Bulb should be insulated using thermal insulation provided to protect it from the effect of the surrounding ambient temperature. Cover completely to insulate from air-stream.

CAUTION

In all cases, mount the TXV bulb after vapor line is brazed and has had sufficient time to cool.

WARNING

*Schrader valve core **MUST NOT** be installed with TXV installation. Poor system performance or system failure could result.*

SECTION V: EVACUATION

It will be necessary to evacuate the system to 500 microns or less. If a leak is suspected, leak test with dry nitrogen to locate the leak. Repair the leak and test again.

To verify that the system has no leaks, simply close the valve to the vacuum pump suction to isolate the pump and hold the system under vacuum. Watch the micron gauge for a few minutes. If the micron gauge indicates a steady and continuous rise, it's an indication of a leak. If the gauge shows a rise, then levels off after a few minutes and remains fairly constant, it's an indication that the system is leak free but still contains moisture and may require further evacuation if the reading is above 500 microns.

SECTION VI: SYSTEM CHARGE

The factory charge in the outdoor unit includes enough charge for the unit, a 15 ft. line set, and the smallest indoor coil match-up. Some indoor coil matches may require additional charge. See tabular data sheet provided in unit literature packet for charge requirements.

CAUTION

Do not leave the system open to the atmosphere.

The "TOTAL SYSTEM CHARGE" must be permanently stamped on the unit data plate.

Total system charge is determined as follows:

1. Determine outdoor unit charge from tabular data sheet.
2. Determine indoor coil adjustment from tabular data sheet.
3. Calculate the line charge using the tabular data sheet if line length is greater than 15 feet.
4. Total system charge = item 1 + item 2 + item 3.
5. Permanently stamp the unit data plate with the total amount of refrigerant in the system.

Use the following charging method whenever additional refrigerant is required for the system charge.

⚠ WARNING

DO NOT attempt to pump "Total System Charge" into outdoor unit for maintenance, service, etc. This may cause damage to the compressor and/or other components. the outdoor unit only has enough volume for the factory charge, not the "Total System Charge".

⚠ CAUTION

Refrigerant charging should only be carried out by a qualified air conditioning contractor.

⚠ CAUTION

Compressor damage will occur if system is improperly charged. On new system installations, charge system per tabular data sheet for the matched coil and follow guidelines in this instruction.

If a calibrated charging cylinder or accurate weighing device is available, add refrigerant accordingly. Otherwise, model-specific charging charts are provided on the access panel of the unit.

SUBCOOLING CHARGING METHOD - TXV INDOOR

For cooling operation, the subcooling values are shown in parentheses on the charging charts provided with the unit.

1. Set the system running in cooling mode by setting the thermostat at least 6°F below the room temperature and operate system for at least 10 – 15 minutes.
2. Refer to the technical guide for the recommended indoor airflow and verify it is correct (it should be about 400 SCFM per ton).

TABLE 2: R-410A Saturation Properties

TEMP. °F	PRESSURE PSIG	TEMP. °F	PRESSURE PSIG	TEMP. °F	PRESSURE PSIG	TEMP. °F	PRESSURE PSIG	TEMP. °F	PRESSURE PSIG
45	130	60	170	75	217	90	274	105	341
46	132	61	173	76	221	91	278	106	345
47	135	62	176	77	224	92	282	107	350
48	137	63	179	78	228	93	287	108	355
49	140	64	182	79	232	94	291	109	360
50	142	65	185	80	235	95	295	110	365
51	145	66	188	81	239	96	299	111	370
52	147	67	191	82	243	97	304	112	375
53	150	68	194	83	247	98	308	113	380
54	153	69	197	84	250	99	313	114	385
55	156	70	201	85	254	100	317	115	391
56	158	71	204	86	258	101	322	116	396
57	161	72	207	87	262	102	326	117	401
58	164	73	211	88	266	103	331	118	407
59	167	74	214	89	270	104	336	119	412

SECTION VII: ELECTRICAL CONNECTIONS

GENERAL INFORMATION & GROUNDING

Check the electrical supply to be sure that it meets the values specified on the unit nameplate and wiring label.

Power wiring, control (low voltage) wiring, disconnect switches and over current protection must be supplied by the installer. Wire size should be sized per NEC requirements.

3. Measure and record the indoor wet bulb (WB) and the outdoor ambient dry bulb (DB) temperature.
4. Using the charging chart located on the unit, find the intersection of the indoor wet bulb and the outdoor dry bulb. This is the recommended liquid pressure (and subcooling value).
5. Measure and record the pressure at the liquid valve pressure port and compare to the value obtained in step 4.
6. Add charge if the measured liquid pressure is lower than the recommended value. Remove / recover charge if the measured liquid pressure is above the recommended value.

Example: The liquid pressure listed at the intersection of the indoor WB and the outdoor DB 320 psig. Pressure at the liquid valve is 305 psig. It would be necessary to add refrigerant to increase the liquid pressure to 320 psig.

Condenser subcooling is obtained by calculating the difference of the saturated refrigerant temperature of the pressure measured at the liquid base valve and the liquid tube temperature as measured at the liquid base valve.

Subcooling Temp. (TC) = Saturated Temp. (TS) – Liquid Temp. (T)

⚠ CAUTION

*IT IS UNLAWFUL TO KNOWINGLY VENT, RELEASE OR DISCHARGE REFRIGERANT INTO THE OPEN AIR DURING REPAIR, SERVICE, MAINTENANCE OR THE FINAL DISPOSAL OF THIS UNIT.
WHEN THE SYSTEM IS FUNCTIONING PROPERLY AND THE OWNER HAS BEEN FULLY INSTRUCTED, SECURE THE OWNER'S APPROVAL.*

⚠ CAUTION

All field wiring must USE COPPER CONDUCTORS ONLY and be in accordance with Local, National, Fire, Safety & Electrical Codes. This unit must be grounded with a separate ground wire in accordance with the above codes.

The complete connection diagram and schematic wiring label is located on the inside surface of the unit service access panel.

FIELD CONNECTIONS POWER WIRING

1. Install the proper size weatherproof disconnect switch outdoors and within sight of the unit.
2. Remove the screw from the field wiring access cover on the service valve end of the unit. Slide the cover down and remove from unit.
3. Run power wiring from the disconnect switch to the unit.
4. Route wires from disconnect through power wiring opening provided and into the top of the field wiring box as shown in Figure 6.
5. Install the proper size time-delay fuses or circuit breaker, and make the power supply connections.

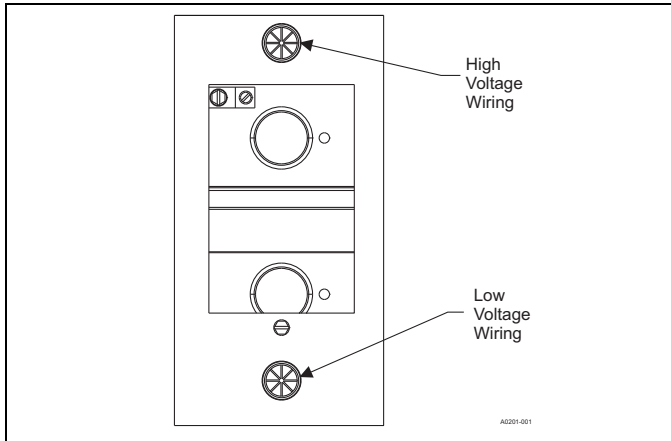

FIGURE 5: Outdoor Unit Field Wiring Control Box

FIELD CONNECTIONS CONTROL WIRING

1. Route low voltage wiring into bottom of field wiring box as shown in Figure 6. Make low voltage wiring connections inside the low voltage box per Figures 8 - 11.
2. The complete connection diagram and schematic wiring label is located on the inside surface of the unit service access panel.
3. Replace the corner cover removed in Step 2.
4. All field wiring to be in accordance with national electrical codes (NEC) and/or local-city codes.

NOTICE

A Start Assist Kit is available for 1-phase units and is recommended for long line set applications or in areas of known low voltage problems.

5. Mount the thermostat about 5 ft. above the floor, where it will be exposed to normal room air circulation. Do not place it on an outside wall or where it is exposed to the radiant effect from exposed glass or appliances, drafts from outside doors or supply air grilles.
6. Route the 24-volt control wiring (NEC Class 2) from the outdoor unit to the indoor unit and thermostat.

NOTICE

To eliminate erratic operation, seal the hole in the wall at the thermostat with permagum or equivalent to prevent air drafts affecting the operation of in the thermostat.

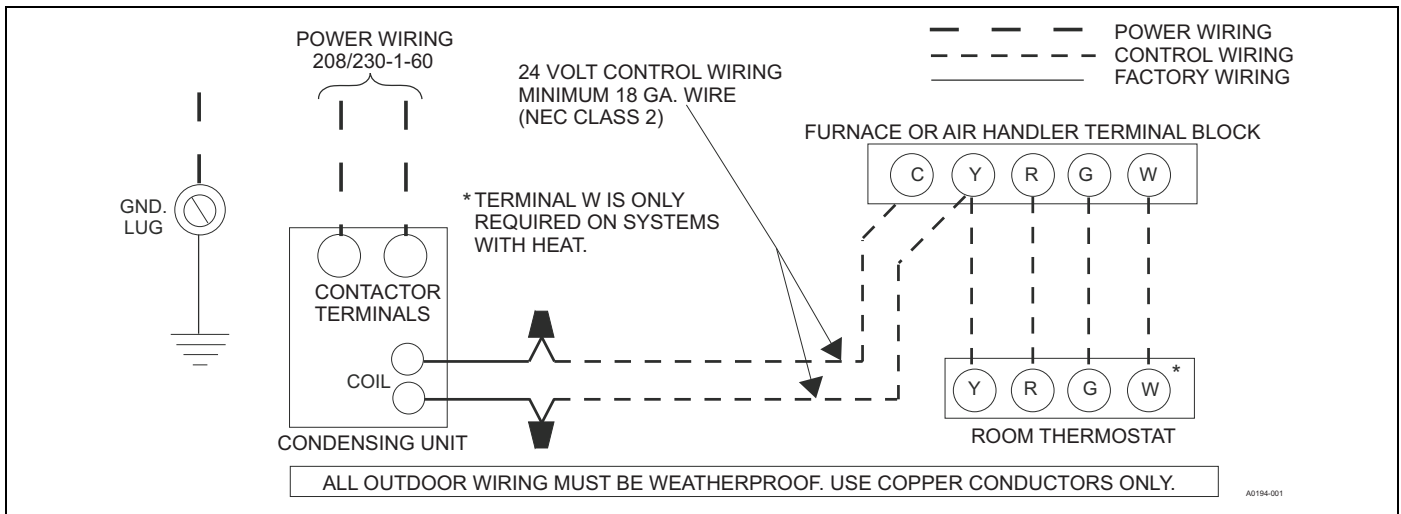

FIGURE 6: Typical Field Wiring (Air Handler / Electrical Heat) (Single-Phase)

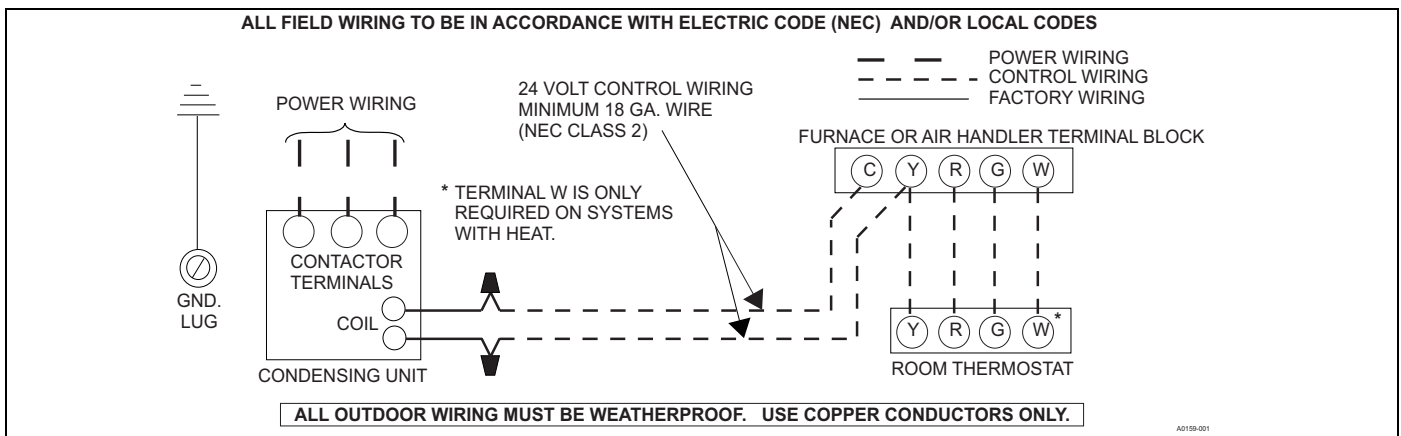

FIGURE 7: Typical Field Wiring (Air Handler / Electrical Heat) (Three-Phase)

For additional connection diagrams for all UPG equipment refer to "Low Voltage System Wiring" document available online at www.upgnet.com in the Product Catalog Section.

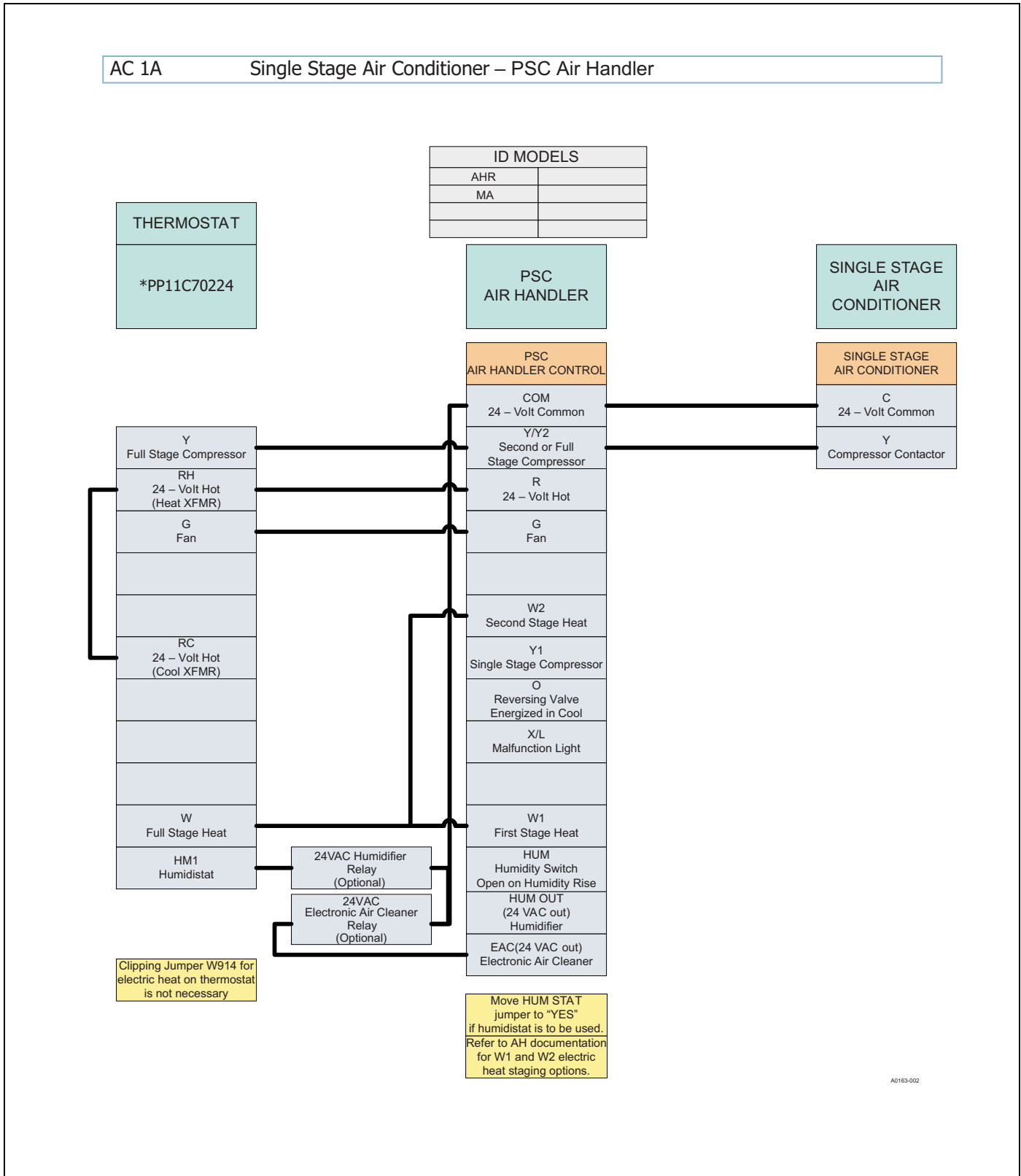

FIGURE 8: Thermostat Chart - Single Stage AC with PSC Air Handler

AC 1B Single Stage Air Conditioner – PSC Air Handler

THERMOSTAT	THERMOSTAT
*BN11C00124	*BP11C50124 *BN11C01124 *DP11C40124 *DN11C00124

ID MODELS	
AHR	
MA	

PSC AIR HANDLER

SINGLE STAGE AIR CONDITIONER

C 24 – Volt Common	C 24 – Volt Common
Y Full Stage Compressor	Y Full Stage Compressor
RH 24 – Volt Hot (Heat XFMR)	RH 24 – Volt Hot (Heat XFMR)
G Fan	G Fan
RC 24 – Volt Hot (Cool XFMR)	RC 24 – Volt Hot (Cool XFMR)
W Full Stage Heat	W Full Stage Heat

PSC AIR HANDLER CONTROL

SINGLE STAGE AIR CONDITIONER

COM 24 – Volt Common
Y/Y2 Second or Full Stage Compressor
R 24 – Volt Hot
G Fan
W2 Second Stage Heat
Y1 Single Stage Compressor
O Reversing Valve Energized in Cool
X/L Malfunction Light
W1 First Stage Heat
HUM Humidity Switch Open on Humidity Rise
HUM OUT (24 VAC out) Humidifier
EAC(24 VAC out) Electronic Air Cleaner

C 24 – Volt Common
Y Compressor Contactor

External Humidistat (Optional)
Open on Humidity Rise

24VAC Humidifier Relay (Optional)
24VAC Electronic Air Cleaner Relay (Optional)

Thermostat Installer Setup
1-System Type-must be set to 0
Thermostat Installer Setup
15-Compressor Protection must be set to 5

Selection of GAS/ELEC switch on thermostat is not necessary

Move HUM STAT jumper to "YES" if humidistat is to be used. Refer to AH documentation for W1 and W2 electric heat staging options.

A0164-002

FIGURE 9: Thermostat Chart - Single Stage AC with PSC Air Handler

AC 5D Single Stage Air Conditioner – Single Stage PSC Furnace

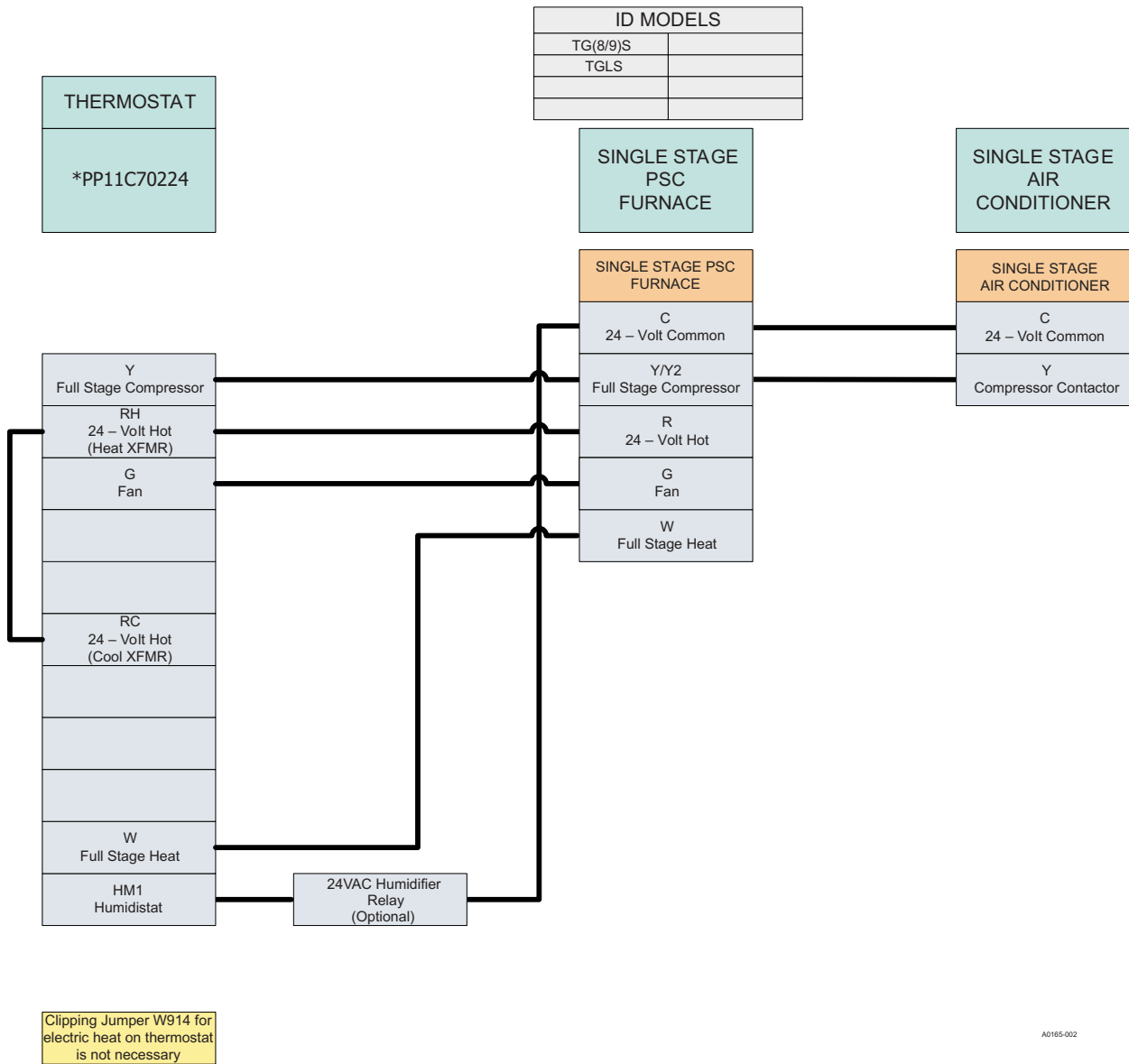
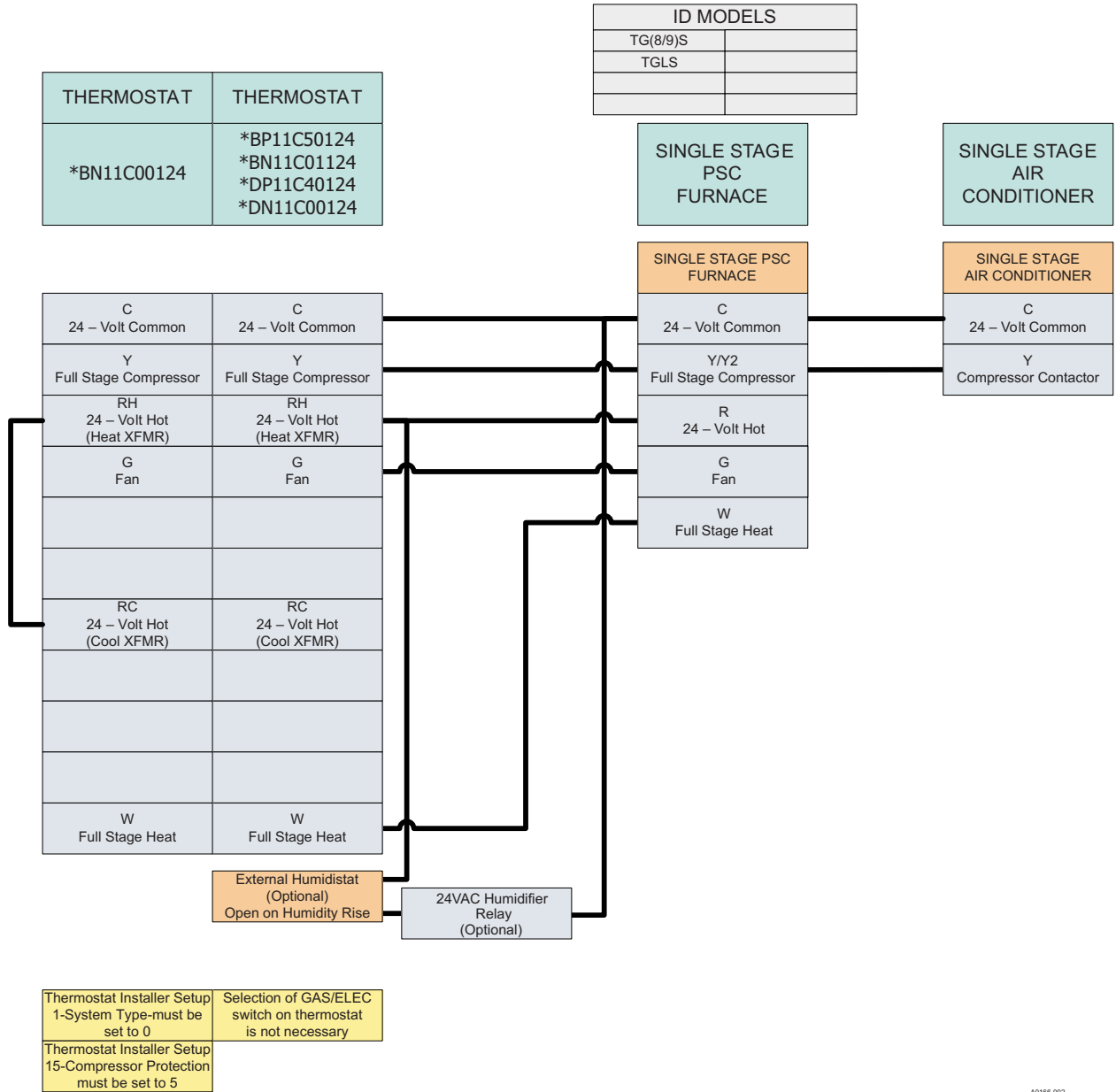

FIGURE 10: Thermostat Chart - Single Stage AC with PSC Furnace

AC 5E Single Stage Air Conditioner – Single Stage PSC Furnace



A0166-002

FIGURE 11: Thermostat Chart - Single Stage AC with PSC Furnace

SECTION VIII: INSTRUCTING THE OWNER

Assist owner with processing warranty cards and/or online registration. Review Owners Guide and provide a copy to the owner and guidance on proper operation and maintenance. Instruct the owner or the operator how to start, stop and adjust temperature setting.

When applicable, instruct the owner that the compressor is equipped with a crankcase heater to prevent the migration of refrigerant to the compressor during the "OFF" cycle. The heater is energized only when the unit is not running. If the main switch is disconnected for long periods of shut down, do not attempt to start the unit until 8 hours after the switch has been connected. This will allow sufficient time for all liquid refrigerant to be driven out of the compressor.

The installer should also instruct the owner on proper operation and maintenance of all other system components.

MAINTENANCE

1. Dirt should not be allowed to accumulate on the outdoor coils or other parts in the air circuit. Clean as often as necessary to keep the unit clean. Use a brush, vacuum cleaner attachment, or other suitable means.
2. The outdoor fan motor is permanently lubricated and does not require periodic oiling.

3. If the coil needs to be cleaned, use clean water to wash dust, dirt, and debris from outdoor condensing coil.

NOTICE

DO NOT use coil cleaners to clean outdoor condensing coil. Cleaners containing HF-, hydroxides, chlorides, and sulfates can greatly reduce the lifetime of the aluminum condensing coil.

4. Refer to the furnace or air handler instructions for filter and blower motor maintenance.
5. The indoor coil and drain pan should be inspected and cleaned regularly to prevent odors and assure proper drainage.

CAUTION

IT IS UNLAWFUL TO KNOWINGLY VENT, RELEASE OR DISCHARGE REFRIGERANT INTO THE OPEN AIR DURING REPAIR, SERVICE, MAINTENANCE OR THE FINAL DISPOSAL OF THIS UNIT.

WHEN THE SYSTEM IS FUNCTIONING PROPERLY AND THE OWNER HAS BEEN FULLY INSTRUCTED, SECURE THE OWNER'S APPROVAL.

SUBCOOLING CHARGE TABLE IS ON THE UNIT RATING PLATE.

SECTION IX: WIRING DIAGRAM

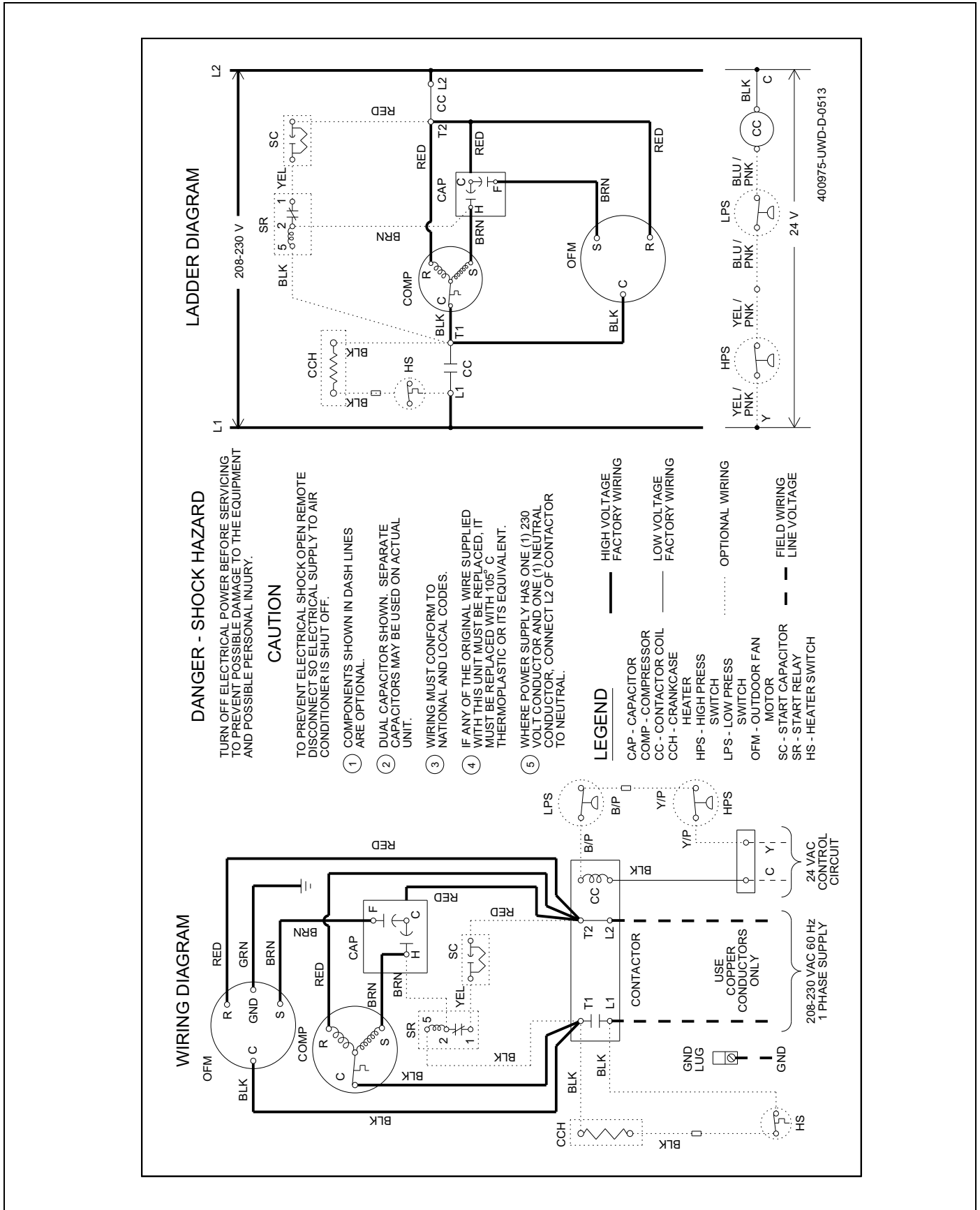

FIGURE 12: Wiring Diagram (Single-Phase)

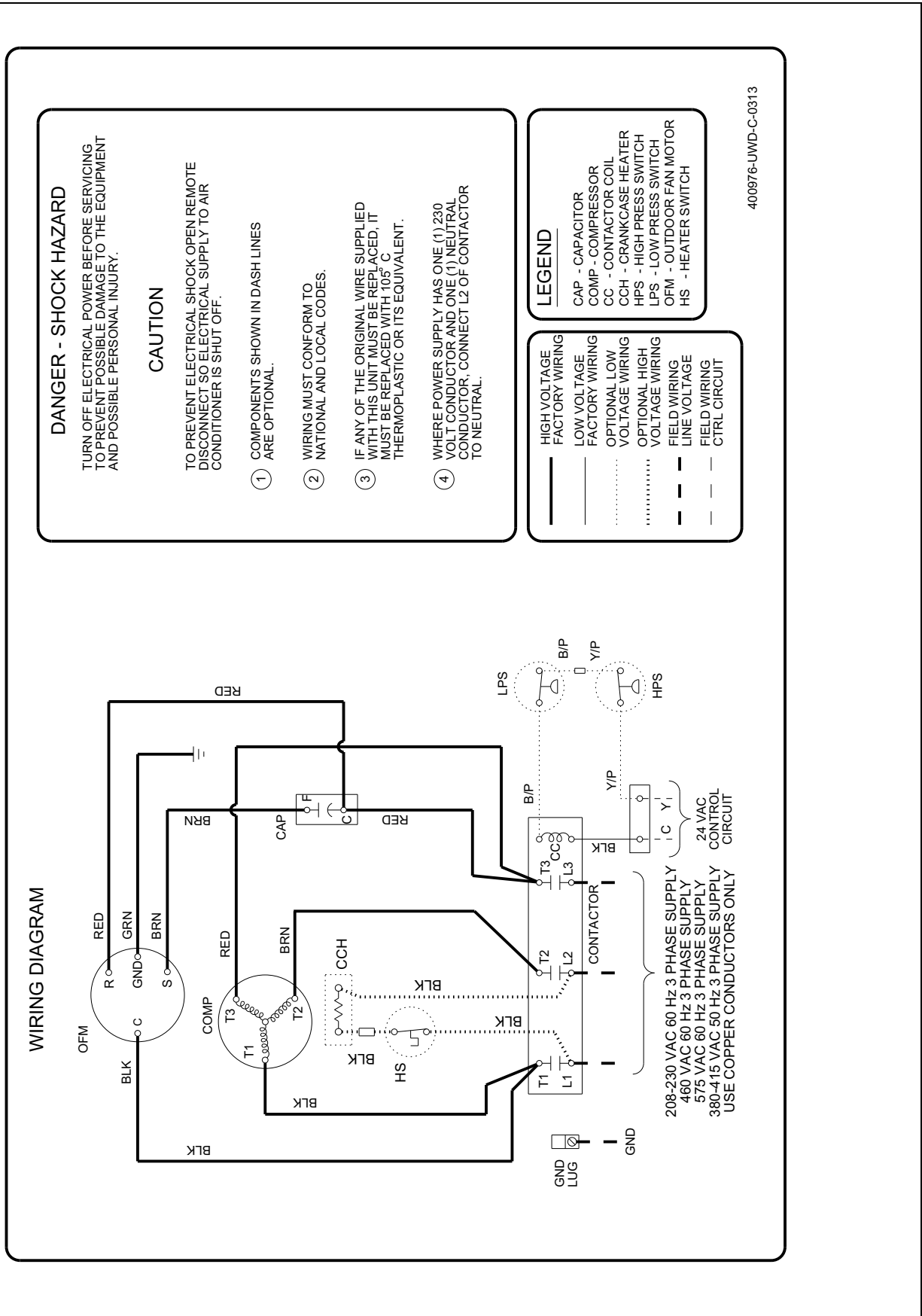

FIGURE 13: Wiring Diagram (Three-Phase)

SECTION X: START UP SHEET

Air Conditioning and Heating Start-Up Sheet Proper start-up is critical to customer comfort and equipment longevity				
<input type="button" value="Print Form"/>			<input type="button" value="Reset Form"/>	
Start-Up Date <input style="width: 80px;" type="text"/>				
Technician Performing Start-Up <input style="width: 150px;" type="text"/>	Installing Contractor Name <input style="width: 150px;" type="text"/>			
Owner Information				
Name <input style="width: 250px;" type="text"/>	Address <input style="width: 350px;" type="text"/>			
City <input style="width: 150px;" type="text"/>	State or Province <input style="width: 150px;" type="text"/>	Zip or Postal Code <input style="width: 100px;" type="text"/>		
Equipment Data				
	<input type="radio"/> Upflow	<input type="radio"/> Downflow	<input type="radio"/> Horizontal Left	<input type="radio"/> Horizontal Right
Indoor Unit Model # <input style="width: 150px;" type="text"/>	Indoor Unit Serial # <input style="width: 150px;" type="text"/>			
Indoor Coil Model # <input style="width: 150px;" type="text"/>	Indoor Coil Serial # <input style="width: 150px;" type="text"/>			
Outdoor Unit Model # <input style="width: 150px;" type="text"/>	Outdoor Unit Serial # <input style="width: 150px;" type="text"/>			
Filter, Thermostat, Accessories				
Filter Type <input style="width: 150px;" type="text"/>	Filter Size <input style="width: 80px;" type="text"/>	Filter Location(s) <input style="width: 150px;" type="text"/>		
Thermostat Type <input style="width: 150px;" type="text"/>	Other System Equipment and Accessories <input style="width: 150px;" type="text"/>			
Connections -- Per Installation Instructions and Local Codes				
<input type="checkbox"/> Unit is level <input type="checkbox"/> Supply plenum and return ducts are connected and sealed <input type="checkbox"/> Refrigerant piping complete and leak tested <input type="checkbox"/> Gas piping is connected (if applicable) <input type="checkbox"/> Vent system is connected (if applicable) <input type="checkbox"/> Condensate drain for indoor coil properly connected <input type="checkbox"/> Condensate drain for furnace (if applicable)				
Electrical: Line Voltage				
Indoor unit (volts AC) <input style="width: 60px;" type="text"/>	Outdoor unit (volts AC) <input style="width: 60px;" type="text"/>	Overcurrent Protection Breaker / Fuses Amperes <input style="width: 100px;" type="text"/>		
<input type="checkbox"/> Ground wire is connected <input type="checkbox"/> Polarity is correct (120vac indoor units) black is L1 (hot), white is N (neutral)				
Electrical: Low Voltage				
<input type="checkbox"/> Thermostat wiring complete		Heat anticipator recommended value	<input style="width: 60px;" type="text"/>	
<input type="checkbox"/> Heat anticipator is set to the recommended value listed in the Installation Instructions				
Low voltage values: "R" and "C" at Indoor unit control board (volts AC) <input style="width: 60px;" type="text"/>		"R" and "C" Outdoor unit control board (volts AC) <input style="width: 60px;" type="text"/>		
Heating Set-Up				
Heating Type <input type="radio"/> Electric Air Handler <input type="radio"/> Natural Gas <input type="radio"/> LP Gas (Requires LP Conversion Kit)				
Inlet Gas Pressure (in. w.c.) <input style="width: 60px;" type="text"/>	Manifold Gas Pressure (in. w.c.) <input style="width: 60px;" type="text"/>	LP Gas Conversion Kit Part # Used <input style="width: 100px;" type="text"/>		
Calculated input in btuh - clock the gas meter (Nat Gas Only) <input style="width: 150px;" type="text"/>		LP Kit Installed By <input style="width: 150px;" type="text"/>		
Electric Heat Kit Part # (if applicable) <input style="width: 100px;" type="text"/>	KW installed <input style="width: 60px;" type="text"/>	Rated BTU/H (furnaces) <input style="width: 100px;" type="text"/>		
Venting (if applicable)				
<input type="checkbox"/> Venting system properly sized, within the limitations of the charts in the installation instructions.				
Intake Size <input style="width: 60px;" type="text"/>	# of 90 Degree Ells <input style="width: 60px;" type="text"/>	# Of 45 Degree Ells <input style="width: 60px;" type="text"/>	Length <input style="width: 60px;" type="text"/>	
Exhaust Size <input style="width: 60px;" type="text"/>	# of 90 Degree Ells <input style="width: 60px;" type="text"/>	# Of 45 Degree Ells <input style="width: 60px;" type="text"/>	Length <input style="width: 60px;" type="text"/>	
Continued on next Page				

Air Side: System Total External Static Pressure

Supply static before indoor coil (in w.c.)	<input type="text"/>	Supply static after indoor coil (in w.c.)	<input type="text"/>
Return Static (in w.c.) before filter	<input type="text"/>	Return Static (in w.c.) after filter (furnace side)	<input type="text"/>
Total External Static Pressure	<input type="text"/>	Maximum Rated ESP (in w.c.)	<input type="text"/>

Cooling Indoor Blower Set-Up	COOL	<input type="radio"/> A	<input type="radio"/> B	<input type="radio"/> C	<input type="radio"/> D	
	ADJUST	<input type="radio"/> A	<input type="radio"/> B	<input type="radio"/> C	<input type="radio"/> D	
	DELAY	<input type="radio"/> A	<input type="radio"/> B	<input type="radio"/> C	<input type="radio"/> D	
	ECM	<input type="radio"/> A	<input type="radio"/> B	<input type="radio"/> C	<input type="radio"/> D	
	X-13	<input type="radio"/> 1	<input type="radio"/> 2	<input type="radio"/> 3	<input type="radio"/> 4	<input type="radio"/> 5
	PSC	<input type="radio"/> Low	<input type="radio"/> Medium Low	<input type="radio"/> Medium	<input type="radio"/> Medium High	<input type="radio"/> High

Return Air: Dry Bulb	<input type="text"/>	Wet Bulb	<input type="text"/>	Supply Air: Dry Bulb	<input type="text"/>	Temperature Drop	<input type="text"/>	Outside Air: Dry Bulb	<input type="text"/>
----------------------	----------------------	----------	----------------------	----------------------	----------------------	------------------	----------------------	-----------------------	----------------------

Heating Indoor Blower Set-Up	HEAT	<input type="radio"/> A	<input type="radio"/> B	<input type="radio"/> C	<input type="radio"/> D			
	ECM	<input type="radio"/> A	<input type="radio"/> B	<input type="radio"/> C	<input type="radio"/> D			
	X-13	<input type="radio"/> 1	<input type="radio"/> 2	<input type="radio"/> 3	<input type="radio"/> 4	<input type="radio"/> 5		
	PSC	<input type="radio"/> Low	<input type="radio"/> Medium Low	<input type="radio"/> Medium	<input type="radio"/> Medium High	<input type="radio"/> High		
	Return Air: Dry Bulb	<input type="text"/>	Wet Bulb	<input type="text"/>	Supply Air: Dry Bulb	<input type="text"/>	Temperature Rise	<input type="text"/>

Refrigerant Charge and Metering Device

<input type="radio"/> R-22	<input type="radio"/> R-410A	<input type="radio"/> TXV	<input type="radio"/> Fixed Orifice	Additional Lineset Length	<input type="text"/>	Adder per foot - lbs.	<input type="text"/>	Oz.	<input type="text"/>		
				# Elbows	<input type="text"/>	# 45s	<input type="text"/>	Total Added - lbs.	<input type="text"/>	Oz.	<input type="text"/>
Orifice Size	<input type="text"/>	Liquid Line Temp	<input type="text"/>	High Side Pressure	<input type="text"/>	Suction Line Temp	<input type="text"/>	Low Side Pressure	<input type="text"/>		
TXV #	<input type="text"/>	Subcooling	<input type="text"/>	Superheat	<input type="text"/>						

Cycle Test

- Operate the unit through continuous fan cycles from the thermostat, noting and correcting any problems
- Operate the unit through a cooling cycles, noting and correcting any problems
- Operate the unit through several heating cycles (if applicable) from the thermostat, noting and correcting any problems

Clean Up

- Installation debris disposed of and indoor and outdoor areas cleaned up?

Owner Education

- Provide owner with the owner's manual
- Explain operation of system to equipment owner
- Explain thermostat use and programming (if applicable) to owner
- Explain the importance of regular filter replacement and equipment maintenance

Comments Section